

Low Profile Air Gripper/ With One Finger Fixed

ø8, ø12, ø16, ø20

New
RoHS

Width

Max. **25%** reduction
40 mm ▶ **30 mm**

* Compared with the existing MHF2 series model, ø12

Weight

Max. **25%** reduction
275 g ▶ **205 g**

* Compared with the existing MHF2 series model, ø12, long stroke

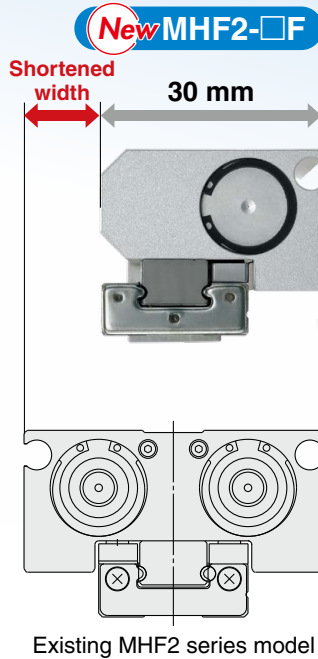

The fixed finger can be set to a reference position.

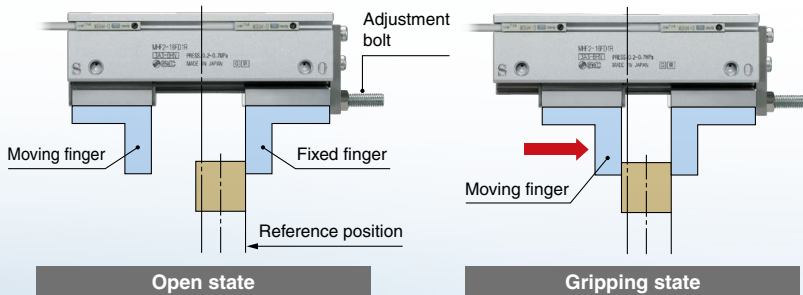

Fixed finger position adjustment function

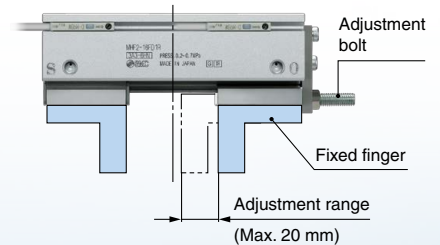

MHF2-□F Series

SMC
CAT.ES20-263A

Compact and lightweight

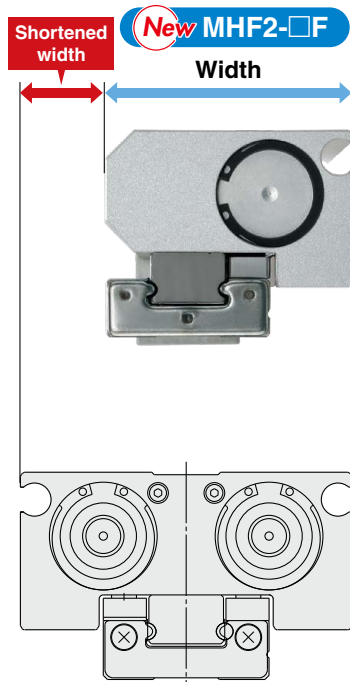

Existing MHF2 series model

Width comparison [mm]

Bore size [mm]		New MHF2-□F	Existing MHF	Difference	Reduction rate
ø8	Short	24.5	32	7.5	23%
	Medium	24.5	32	7.5	23%
	Long	24.5	32	7.5	23%
ø12	Short	30	40	10	25%
	Medium	30	40	10	25%
	Long	30	40	10	25%
ø16	Short	38.5	50	11.5	23%
	Medium	38.5	50	11.5	23%
	Long	38.5	50	11.5	23%
ø20	Short	47	62	15	24%
	Medium	47	62	15	24%
	Long	47	62	15	24%

Weight comparison [g]

Bore size [mm]		New MHF2-□F	Existing MHF	Difference	Reduction rate
ø8	Short	55	65	10	15%
	Medium	70	85	15	18%
	Long	95	120	25	21%
ø12	Short	120	155	35	23%
	Medium	145	190	45	24%
	Long	205	275	70	25%
ø16	Short	275	350	75	21%
	Medium	345	445	100	22%
	Long	490	650	160	25%
ø20	Short	505	645	140	22%
	Medium	635	850	215	25%
	Long	905	1225	320	26%

Fixed finger position adjustment function

Fine adjustment is possible by using the adjustment bolt.

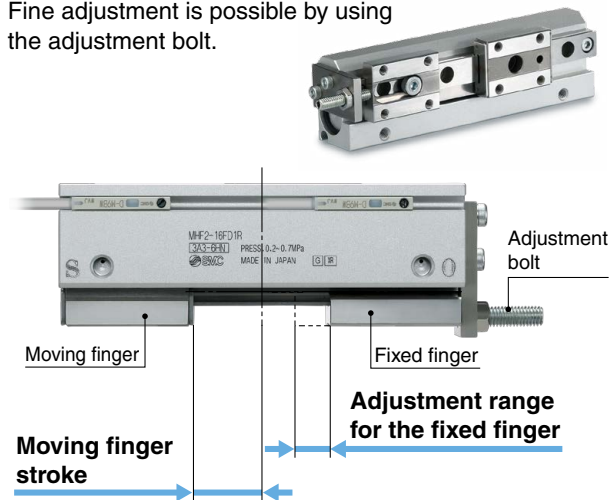

Bore size		Moving finger stroke	Adjustment range for the fixed finger
ø8	Short	4	2
	Medium	8	4
	Long	16	8
ø12	Short	6	3
	Medium	12	6
	Long	24	12
ø16	Short	8	4
	Medium	16	8
	Long	32	16
ø20	Short	10	5
	Medium	20	10
	Long	40	20



Positioning pin holes have been standardized. 3 types of mounting are possible.

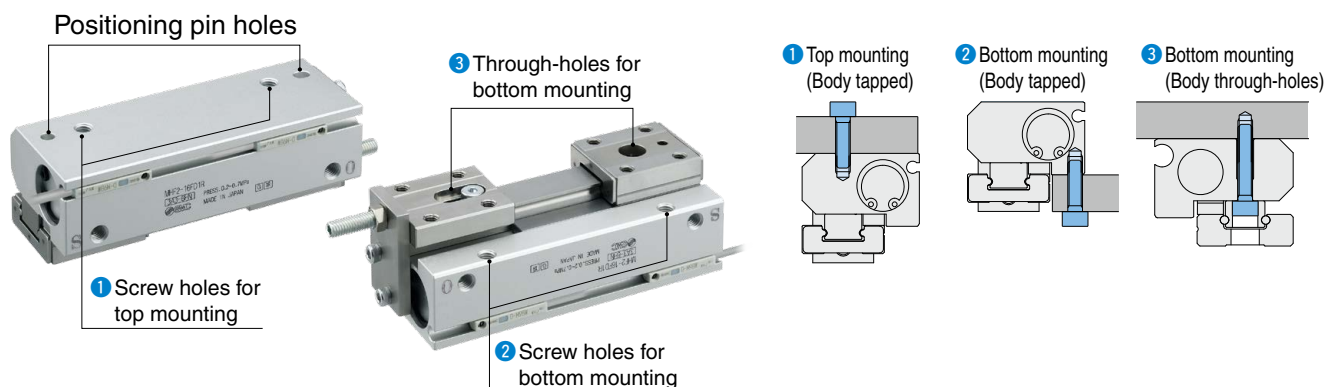

3 stroke lengths can be selected for moving finger.

3 standard stroke lengths are available for each bore size. Stroke can be selected to suit the workpiece.

Bore size [mm]	ø8	ø12	ø16	ø20
Short	4 mm	6 mm	8 mm	10 mm
Medium	8 mm	12 mm	16 mm	20 mm
Long	16 mm	24 mm	32 mm	40 mm

Compact solid state auto switches are mountable.



Solid state auto switch: D-M9□

CONTENTS

Low Profile Air Gripper/With One Finger Fixed **MHF2-□F Series**

Model Selection	p. 3	Dimensions	p. 10
How to Order	p. 7	Auto Switch Installation Examples and Mounting Positions	p. 22
Specifications	p. 8	Specific Product Precautions	p. 25
Replacement Parts	p. 9		

MHF2-□F Series Model Selection

Model Selection

Selection Procedure



Step 1 Check the gripping force.



Example

Workpiece mass:
0.15 kg

Gripping method:
External gripping

Guidelines for the selection of the gripper with respect to workpiece mass

- Although conditions differ according to the workpiece shape and the coefficient of friction between the attachments and the workpiece, select a model that can provide a gripping force of at least 10 to 20 times*1 greater than the workpiece weight. *1 For further details, refer to the model selection illustration.
- Further allowance should be provided when great acceleration or impact is expected during workpiece transfer.

Calculation example

For setting the gripping force to be at least 20 times greater than the workpiece weight:
Required gripping force = 0.15 kg x 20 x 9.8 m/s² ≈ 29.4 N or more

Gripping point distance:
30 mm

Operating pressure:
0.4 MPa

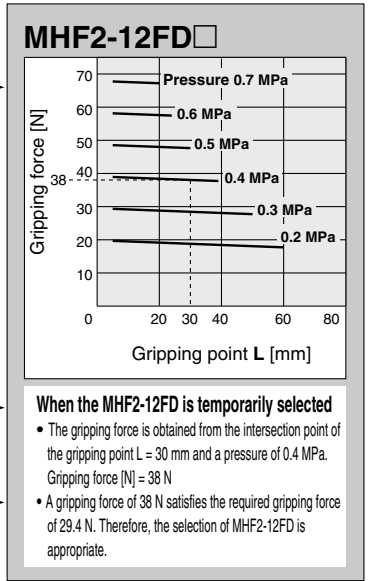

Model Selection Illustration

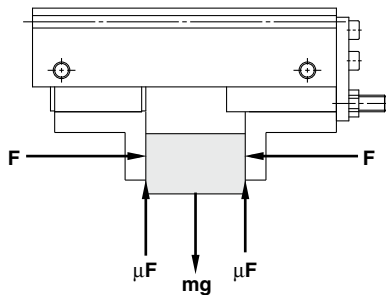

“Gripping force at least 10 to 20 times greater than the workpiece weight”
“At least 10 to 20 times greater than the workpiece weight” recommended by SMC is calculated with a margin of “a” = 4, which allows for impacts that occur during normal transportation, etc.

When $\mu = 0.2$	When $\mu = 0.1$
$F = \frac{mg}{2 \times 0.2} \times 4$ $= 10 \times mg$	$F = \frac{mg}{2 \times 0.1} \times 4$ $= 20 \times mg$

10 x Workpiece weight

20 x Workpiece weight

- * Even in cases where the coefficient of friction is greater than $\mu = 0.2$, for reasons of safety, select a gripping force which is at least 10 to 20 times greater than the workpiece weight, as recommended by SMC.
- * If high acceleration, or impact forces are encountered during motion, a further margin should be considered.

When gripping a workpiece as in the figure to the left, and with the following definitions,
F: Gripping force [N]
 μ : Coefficient of friction between the attachments and the workpiece
m: Workpiece mass [kg]
g: Gravitational acceleration (9.8 m/s²)
mg: Workpiece weight [N]

the conditions under which the workpiece will not drop are

$$2 \times \mu F > mg$$

Number of fingers

and therefore,

$$F > \frac{mg}{2 \times \mu}$$

With “a” representing the margin,
“F” is determined by the following formula:

$$F = \frac{mg}{2 \times \mu} \times a$$

* The number of fingers for the fixed finger gripper shall be 2 because the finger grips an object by reaction force.

Model Selection

Step 1 Check the effective gripping force: MHF2-□F Series

- Indication of effective gripping force
The gripping force shown in the graphs below represents the gripping force of one finger when all fingers and attachments are in contact with the workpiece.
F = One finger thrust
- Both the external and internal gripping forces are the values shown in the graphs below.

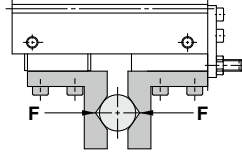

External gripping state

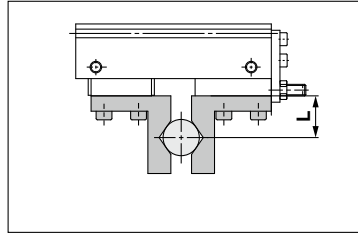

Internal gripping state

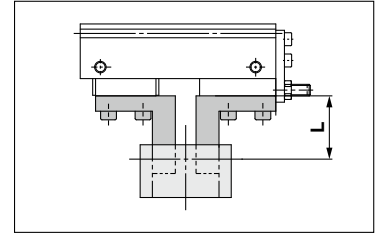

MHF2-8FD□

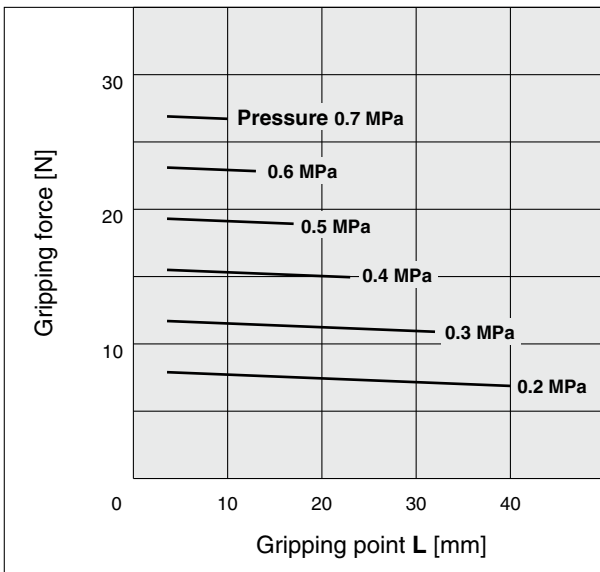

MHF2-12FD□

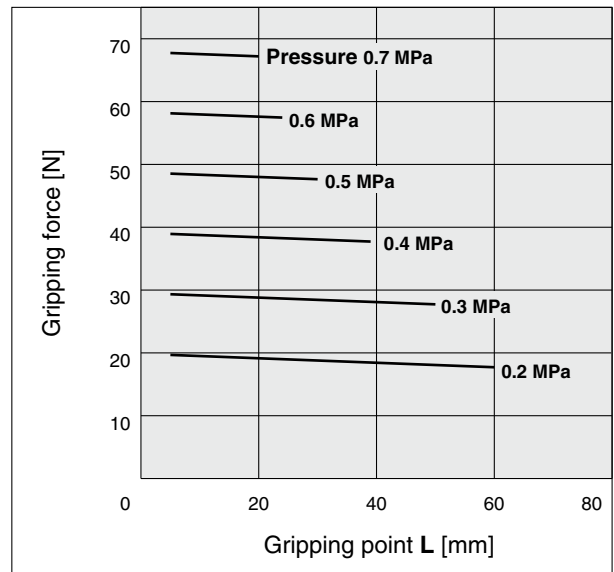

MHF2-16FD□

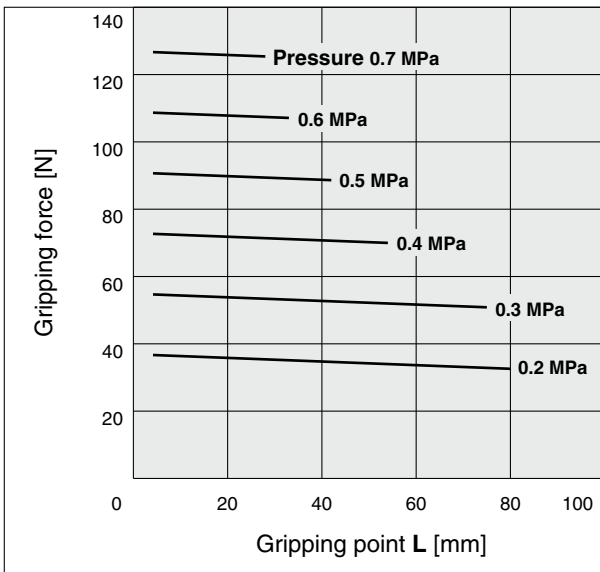

MHF2-20FD□

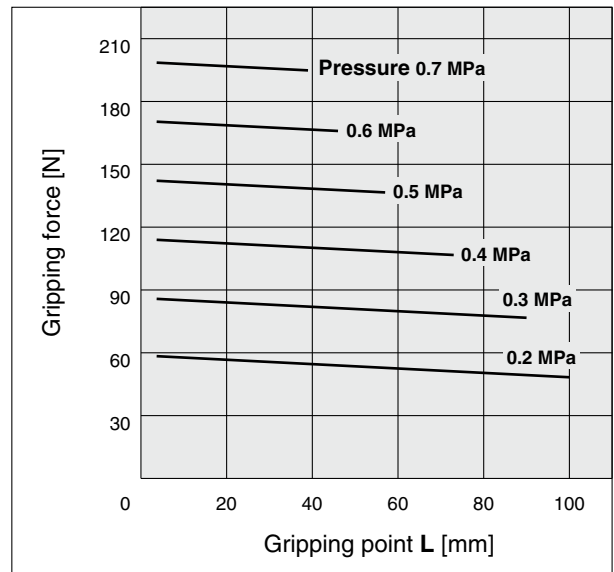

MHF2-□F Series

Model Selection

Step 2 Check the gripping point: MHF2-□F Series

External gripping state

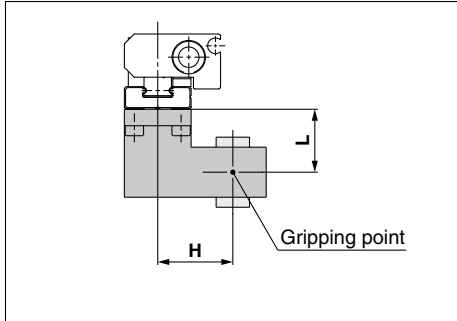

Internal gripping state

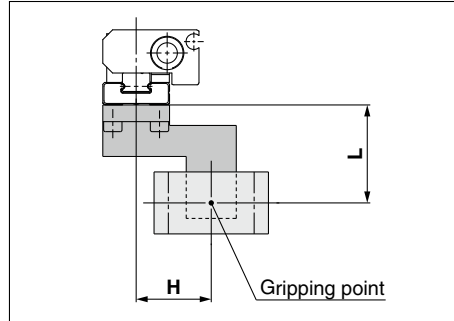

- The air gripper should be operated so that the workpiece gripping point "L" and the amount of overhang "H" stay within the range shown for each operating pressure given in the graphs below.
- If the workpiece gripping point goes beyond the range limits, this will have an adverse effect on the life of the air gripper.

MHF2-8FD□

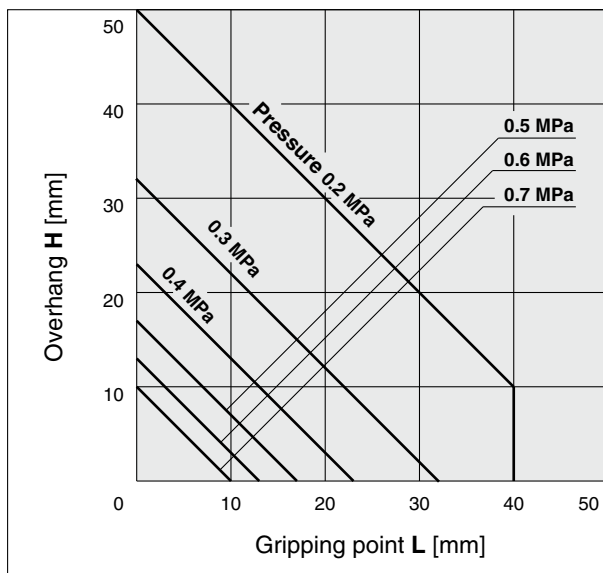

MHF2-12FD□

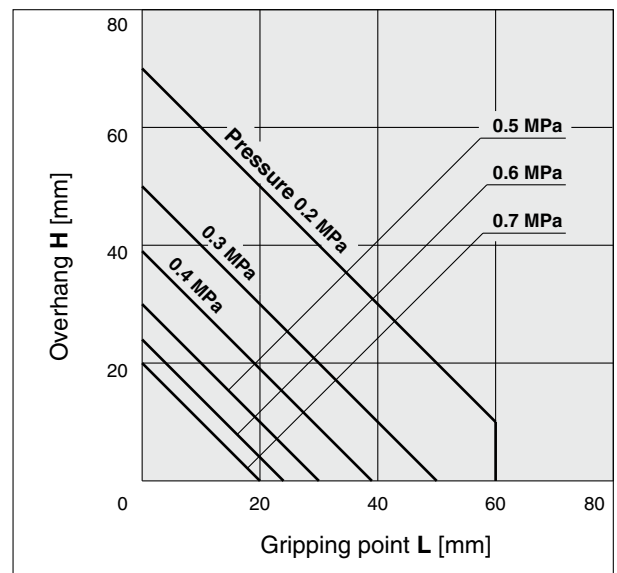

MHF2-16FD□

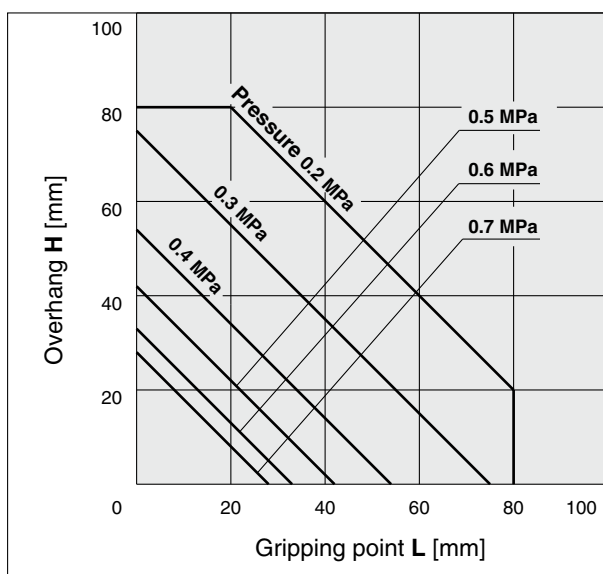

MHF2-20FD□

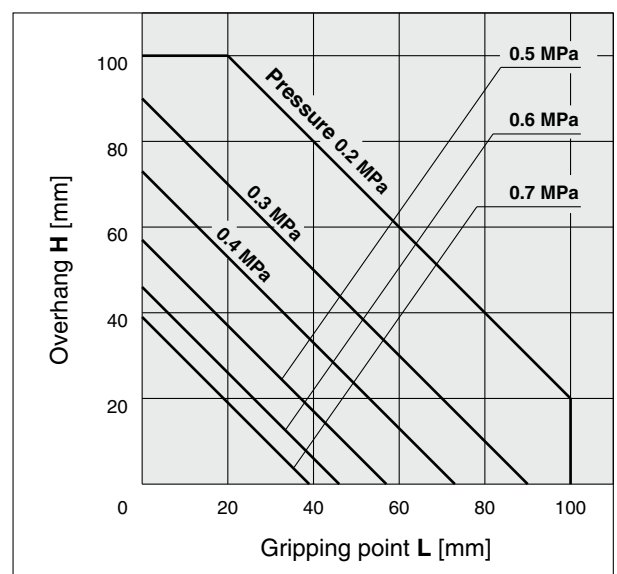

Model Selection

Step 3 Check the external force on fingers: MHF2-□F Series

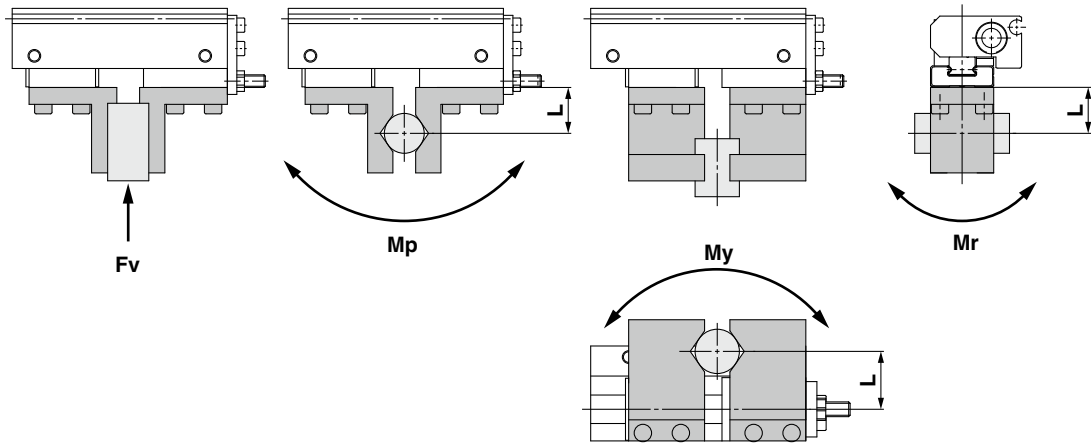

L: Distance to the point at which the load is applied [mm]

Model	Allowable vertical load Fv [N]	Max. allowable moment		
		Pitch moment Mp [N·m]	Yaw moment My [N·m]	Roll moment Mr [N·m]
MHF2-8FD □	58	0.26	0.26	0.53
MHF2-12FD □	98	0.68	0.68	1.4
MHF2-16FD □	176	1.4	1.4	2.8
MHF2-20FD □	294	2	2	4

* The load and moment values in the table indicate static values.

Calculation of allowable external force (when moment load is applied)	Calculation example
$\text{Allowable load } F \text{ [N]} = \frac{M \text{ (Max. allowable moment) [N·m]}}{L \times 10^{-3*1}}$ <p>(*1 Constant for unit conversion)</p>	<p>When a load $f = 10 \text{ N}$ is operating, which applies pitch moment to point $L = 30 \text{ mm}$ from the end of the MHF2-12FD finger.</p> $\text{Allowable load } F = \frac{0.68}{30 \times 10^{-3}}$ $= 22.7 \text{ [N]}$ <p>Load $f = 10 \text{ [N]} < 22.7 \text{ [N]}$</p> <p>Therefore, it can be used.</p>

Step 4 Check the kinetic energy.

Mass of Moving Parts: M1 [g]

Model	Stroke		
	D: Short	D1: Medium	D2: Long
MHF2-8F □	12	14	20
MHF2-12F □	27	33	47
MHF2-16F □	61	76	108
MHF2-20F □	111	140	200

Allowable Kinetic Energy: E [J]

Model	Allowable kinetic energy
MHF2-8FD □	0.0019
MHF2-12FD □	0.0033
MHF2-16FD □	0.0045
MHF2-20FD □	0.007

Calculation of kinetic energy	Calculation example
$E = \frac{M_1 + M_2}{2} \times V^2 \times 10^{-9*1}$ <p>(*1 Constant for unit conversion)</p> <p>E: Kinetic energy [J] M1: Mass of moving parts [g] M2: Mass of the attachment on the moving finger [g] V: Average operating speed [mm/s] * Average operating speed: Speed calculated by dividing the stroke by the time from starting operation until reaching the end</p>	<p>When the product is operated at average operating speed of 200 mm/s with a 100 g attachment mounted to the moving finger of MHF2-12FD, the equation will be as follows.</p> $E = \frac{27 + 100}{2} \times 200^2 \times 10^{-9}$ $= 0.0025 \text{ [J]}$ <p>Therefore, it can be used.</p>

* If the allowable kinetic energy value is exceeded, this will have an adverse effect on the life of the air gripper. Control the opening/closing speed with the speed controller to avoid excessive high-speed operation.

Low Profile Air Gripper/With One Finger Fixed

MHF2-□F Series

∅8, ∅12, ∅16, ∅20

RoHS

How to Order

MHF2-12FD□R-M9BW□

Number of fingers

2	2
---	---

Bore size [mm]

8	8
12	12
16	16
20	20

F One finger fixed

Action

D	Double acting
----------	---------------

Stroke

Nil	Short stroke
1	Medium stroke
2	Long stroke

* For details, refer to the "Model" chart on page 8.

Number of auto switches

Nil	2
S	1
n	n

Auto switch

Nil	Without auto switch (Built-in magnet)
------------	---------------------------------------

* For applicable auto switches, refer to the table below.

Piping position

Applicable Auto Switches/Refer to the Web Catalog or Best Pneumatics Catalog for further information on auto switches.

Type	Special function	Electrical entry	Indicator light	Wiring (Output)	Load voltage		Auto switch model		Lead wire length [m]				Pre-wired connector	Applicable load	
					DC	AC	Perpendicular	In-line	0.5 (Nil)	1 (M)	3 (L)	5 (Z)		IC circuit	Relay, PLC
Solid state auto switch	—	Grommet	Yes	3-wire (NPN)	5 V, 12 V	—	M9NV	M9N	●	●	●	○	○	IC circuit	Relay, PLC
				3-wire (PNP)			M9PV	M9P	●	●	●	○			
				2-wire	M9BV		M9B	●	●	●	○				
	Diagnostic indication (2-color indicator)			3-wire (NPN)	5 V, 12 V		M9NWV	M9NW	●	●	●	○	○	IC circuit	
				3-wire (PNP)			M9PWV	M9PW	●	●	●	○	○	IC circuit	
	Water resistant (2-color indicator)			2-wire	12 V		M9B WV	M9B W	●	●	●	○	○	—	
				3-wire (NPN)	5 V, 12 V		M9NAV*1	M9NA*1	○	○	●	○	○	IC circuit	
				3-wire (PNP)			M9PAV*1	M9PA*1	○	○	●	○	○	—	
				2-wire	12 V		M9BAV*1	M9BA*1	○	○	●	○	○	—	

*1 Water-resistant type auto switches can be mounted on the above models, but SMC cannot guarantee water resistance.

* Solid state auto switches marked with "○" are produced upon receipt of order.

* Lead wire length symbols: 0.5 m..... Nil (Example) M9NW
 1 m..... M (Example) M9NWM
 3 m..... L (Example) M9NWL
 5 m..... Z (Example) M9NWZ

* When using the 2-color indicator type, please make the setting so that the indicator is lit in red to ensure the detection at the proper position of the air gripper.

Specifications



Fluid		Air
Operating pressure		0.2 to 0.7 MPa
Ambient and fluid temperatures		-10 to 60°C (No freezing)
Max. operating frequency	Short stroke	120 c.p.m.
	Medium stroke	120 c.p.m.
	Long stroke	60 c.p.m.
Lubricant		Non-lube
Action		Double acting
Auto switch (Option)		Solid state auto switch (3-wire, 2-wire)

Model

Symbol

Double acting, Internal grip

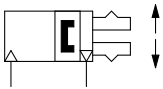

Double acting, External grip

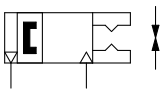

Refer to pages 22 to 24 for cylinders with auto switches.

- Auto Switch Installation Examples and Mounting Positions
- Auto Switch Hysteresis
- Auto Switch Mounting
- Protrusion of Auto Switch from Edge of Body

Action	Model	Bore size [mm]	Gripping force*1		Opening/Closing stroke (One side) [mm]	Stroke adjuster adjustment range [mm]	Weight*2 [g]	Volume [cm ³]	
			Effective gripping force per finger [N]					Finger open side	Finger close side
Double acting	MHF2-8FDR	8	19		4	2	55	0.3	0.3
	MHF2-8FD1R				8	4	70	0.5	0.5
	MHF2-8FD2R				16	8	95	0.9	0.9
	MHF2-12FDR	12	48		6	3	120	0.7	0.7
	MHF2-12FD1R				12	6	145	1.4	1.4
	MHF2-12FD2R				24	12	205	2.8	2.8
	MHF2-16FDR	16	90		8	4	275	1.7	1.7
	MHF2-16FD1R				16	8	345	3.3	3.3
	MHF2-16FD2R				32	16	490	6.5	6.5
	MHF2-20FDR	20	141		10	5	505	3.2	3.2
	MHF2-20FD1R				20	10	635	6.3	6.3
	MHF2-20FD2R				40	20	905	12.6	12.6

*1 At the pressure of 0.5 MPa, when gripping point L is 20 mm

*2 Excluding the auto switch weight

Moisture Control Tube IDK Series



When operating an actuator with a small bore size and a short stroke at a high frequency, dew condensation (water droplets) may occur inside the piping depending on the conditions. Simply connecting the moisture control tube to the actuator will prevent dew condensation from occurring. For details, refer to **the IDK series in the Best Pneumatics No. 6 Catalog**.

MHF2-□F Series

Replacement Parts

MHF2-8FD□R

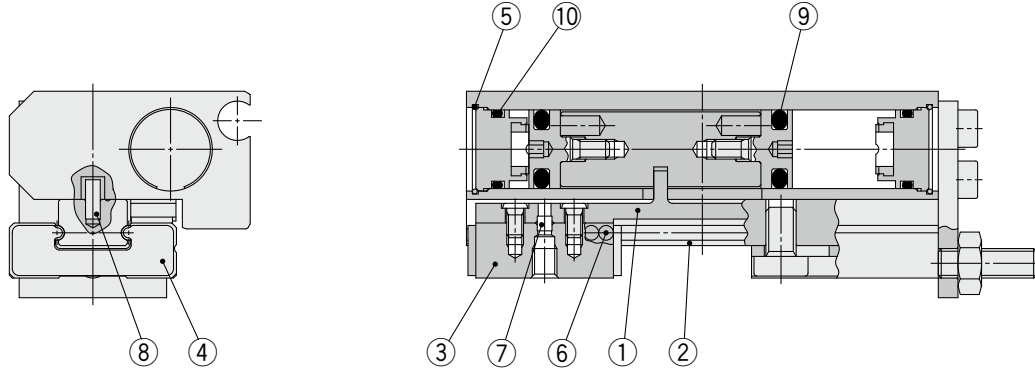

MHF2-12FD□R to MHF2-20FD□R

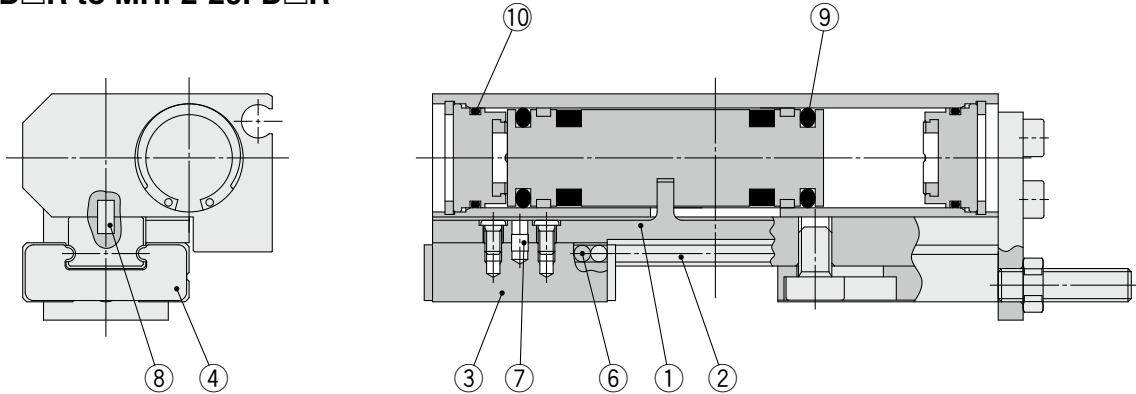

Component Parts

No.	Description
1	Joint
2	Guide rail
3	Finger
4	Roller stopper
5	Clip
6	Steel ball
7	Roller (ø8, ø12) Parallel pin (ø16, ø20)
8	Parallel pin
9	Piston seal
10	Gasket

Seal Kit

Model	Kit no.	Contents
MHF2-8FDR	MHF8F-PS	⑤ ⑨ ⑩
MHF2-8FD1R		
MHF2-8FD2R		
MHF2-12FDR	MHF12F-PS	⑨ ⑩
MHF2-12FD1R		
MHF2-12FD2R		
MHF2-16FDR	MHF16F-PS	⑨ ⑩
MHF2-16FD1R		
MHF2-16FD2R		
MHF2-20FDR	MHF20F-PS	⑨ ⑩
MHF2-20FD1R		
MHF2-20FD2R		

Finger Assembly

Model	Kit no.	Contents
MHF2-8FDR	MHF-AA0802F	① ② ③ ④ ⑥ ⑦ ⑧ Guide rail mounting screw
MHF2-8FD1R	MHF-AA0802F-1	
MHF2-8FD2R	MHF-AA0802F-2	
MHF2-12FDR	MHF-AA1202F	① ② ③ ④ ⑥ ⑦ ⑧ Guide rail mounting screw
MHF2-12FD1R	MHF-AA1202F-1	
MHF2-12FD2R	MHF-AA1202F-2	
MHF2-16FDR	MHF-AA1602F	① ② ③ ④ ⑥ ⑦ ⑧ Guide rail mounting screw
MHF2-16FD1R	MHF-AA1602F-1	
MHF2-16FD2R	MHF-AA1602F-2	
MHF2-20FDR	MHF-AA2002F	① ② ③ ④ ⑥ ⑦ ⑧ Guide rail mounting screw
MHF2-20FD1R	MHF-AA2002F-1	
MHF2-20FD2R	MHF-AA2002F-2	

Grease Pack

* The seal kit does not include a grease pack. Order it separately.
 Guide unit: GR-S-010 (10 g)
 Cylinder unit: GR-L-005 (5 g)

MHF2-□F Series

Dimensions

MHF2-8FD1R

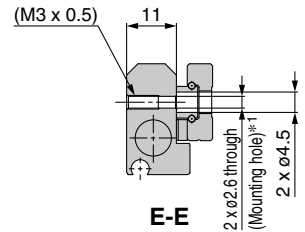
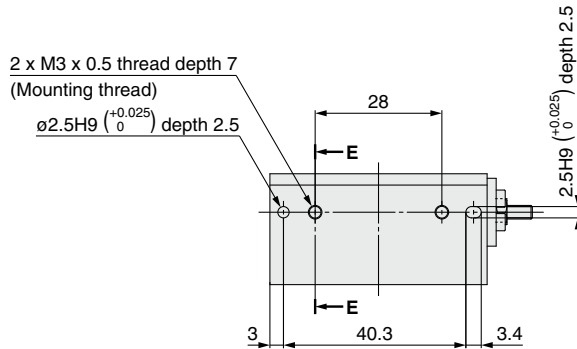

*1 Use the attached hexagon socket head cap screws for body through-hole mounting.

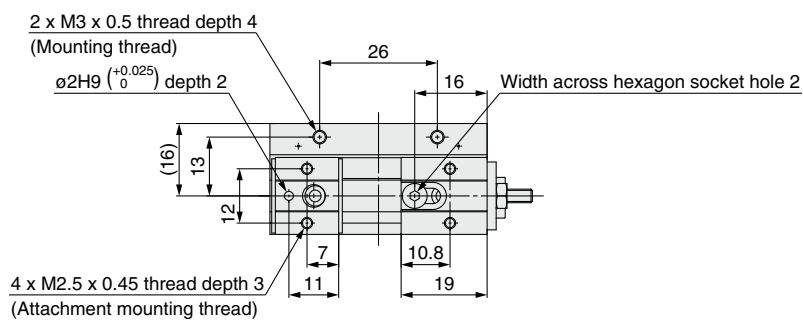
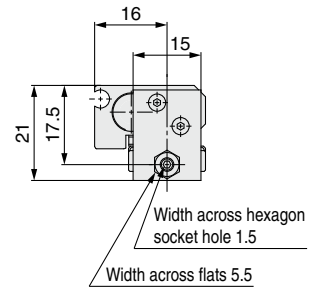
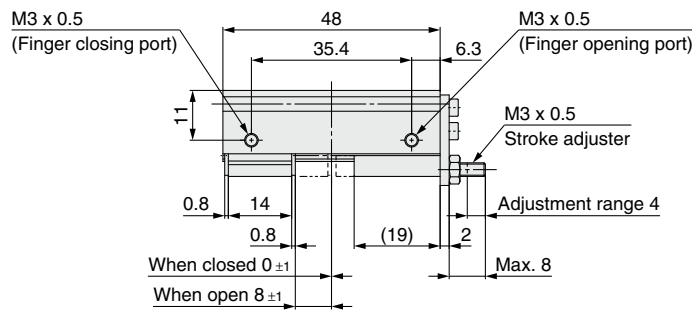
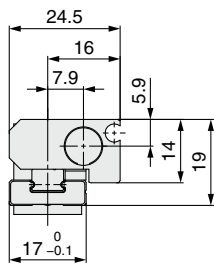

Dimensions of auto switch mounting groove

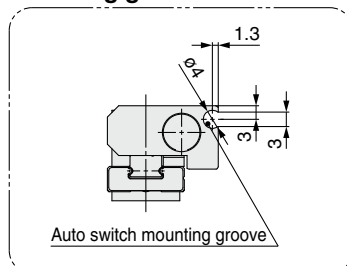

Accessory:
Hexagon socket head cap screw
for body through-hole mounting
(2 special screws are included.)

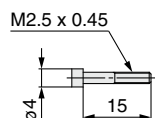

* Special screws for body through-hole mounting are attached to the product. They are also provided at an order of 1 piece or more with the part number shown below.

Order no.	No. of screws
MHF-B08	2 pcs./unit

Dimensions

MHF2-8FD2R

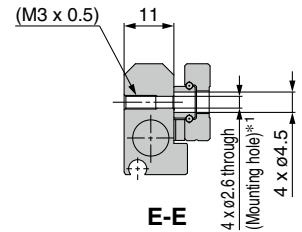
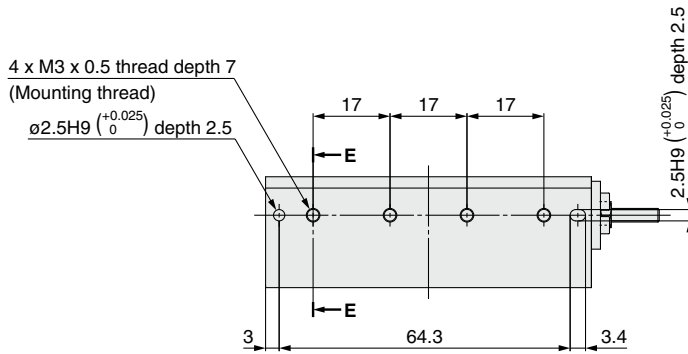

*1 Use the attached hexagon socket head cap screws for body through-hole mounting.

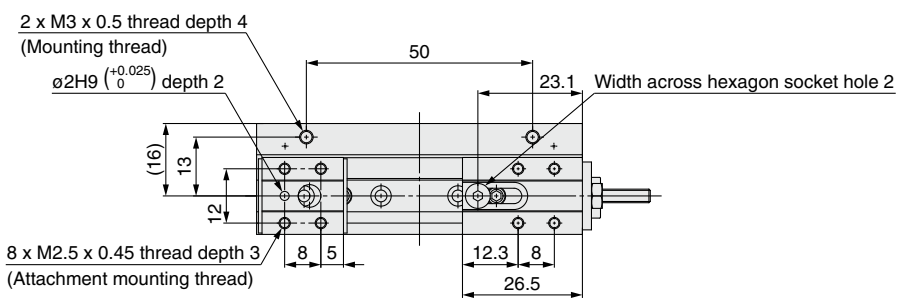
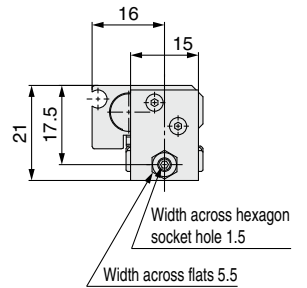
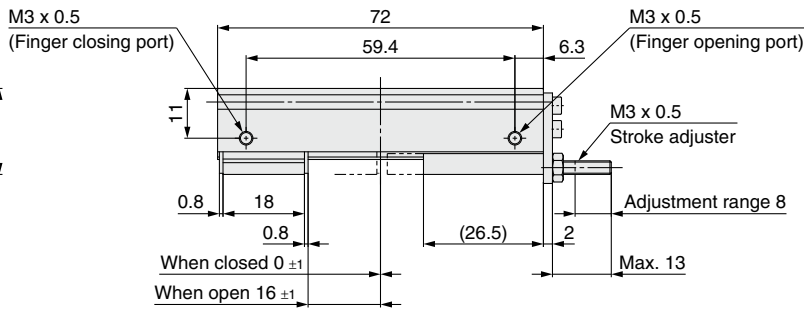
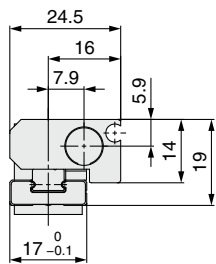

Dimensions of auto switch mounting groove

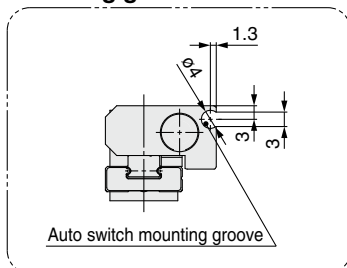

Accessory:
Hexagon socket head cap screw
for body through-hole mounting
(4 special screws are included.)

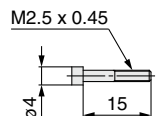

* Special screws for body through-hole mounting are attached to the product. They are also provided at an order of 1 piece or more with the part number shown below.

Order no.	No. of screws
MHF-B08	4 pcs./unit

MHF2-□F Series

Dimensions

MHF2-12FDR

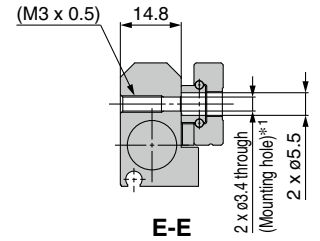
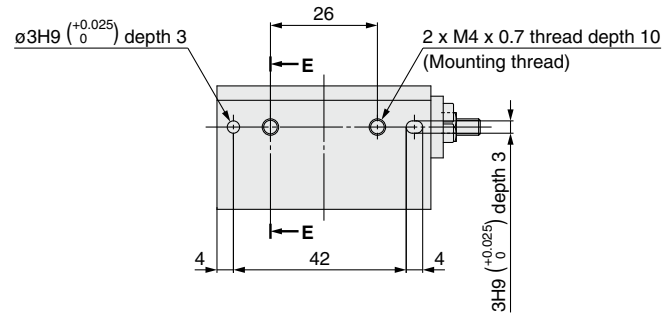

*1 Use the attached hexagon socket head cap screws for body through-hole mounting.

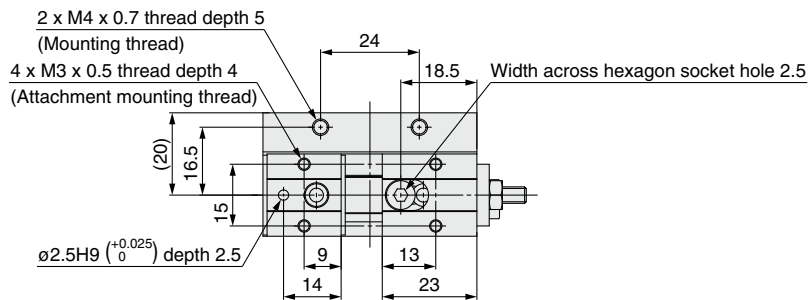
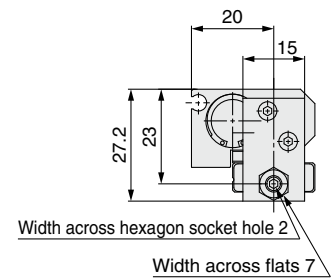
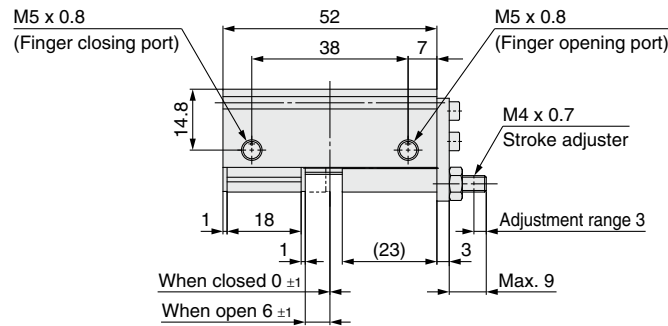
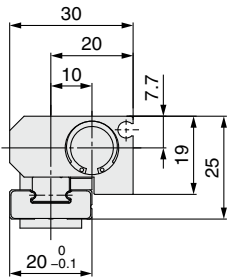

Dimensions of auto switch mounting groove

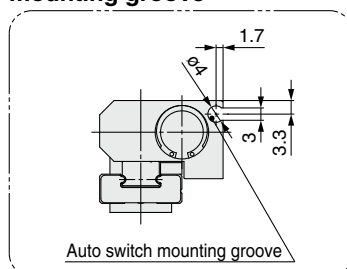

Accessory:
Hexagon socket head cap screw for body through-hole mounting (2 special screws are included.)

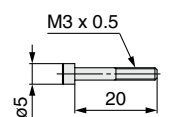

* Special screws for body through-hole mounting are attached to the product. They are also provided at an order of 1 piece or more with the part number shown below.

Order no.	No. of screws
MHF-B12	2 pcs./unit

Dimensions

MHF2-16FDR

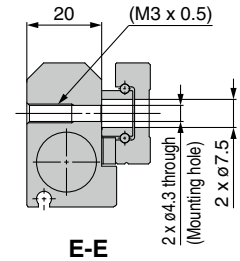
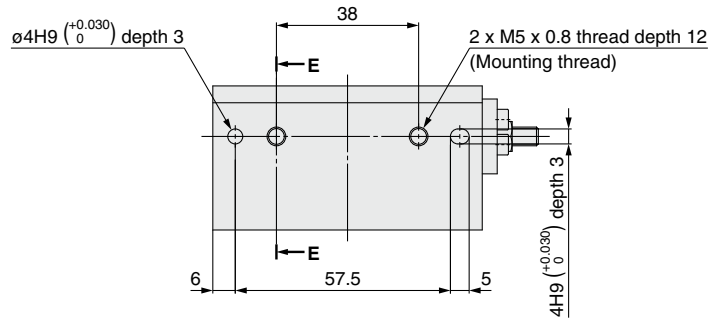

* Use the commercially available hexagon socket head cap screws for body through-hole mounting.

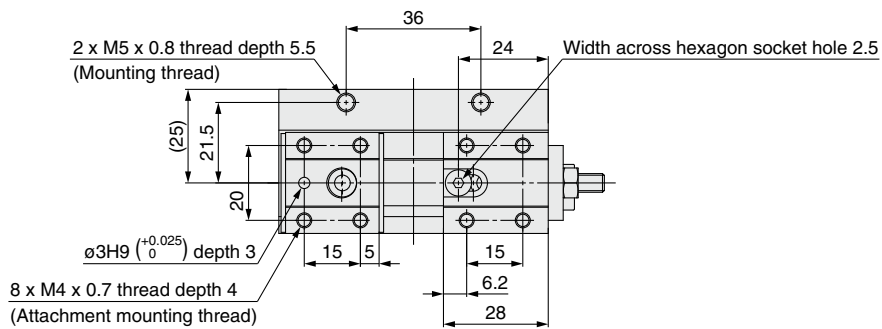
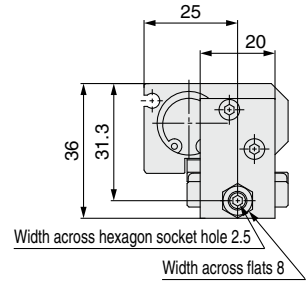
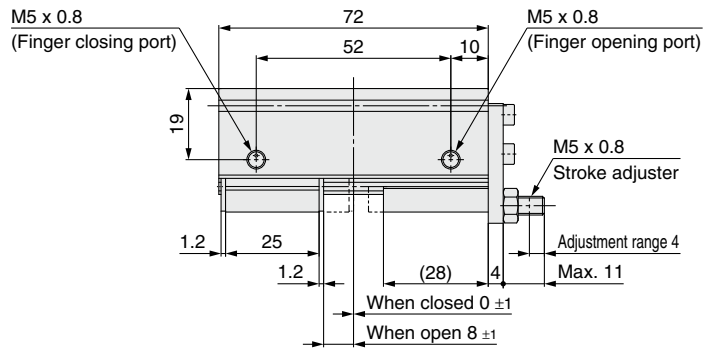
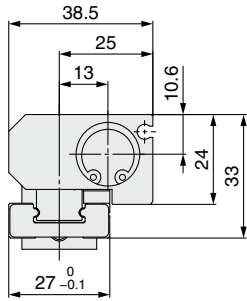

Dimensions of auto switch mounting groove

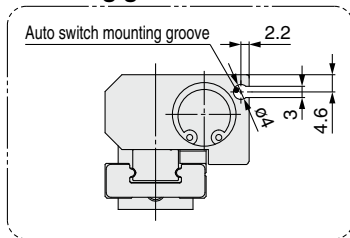

Dimensions

MHF2-20FD1R

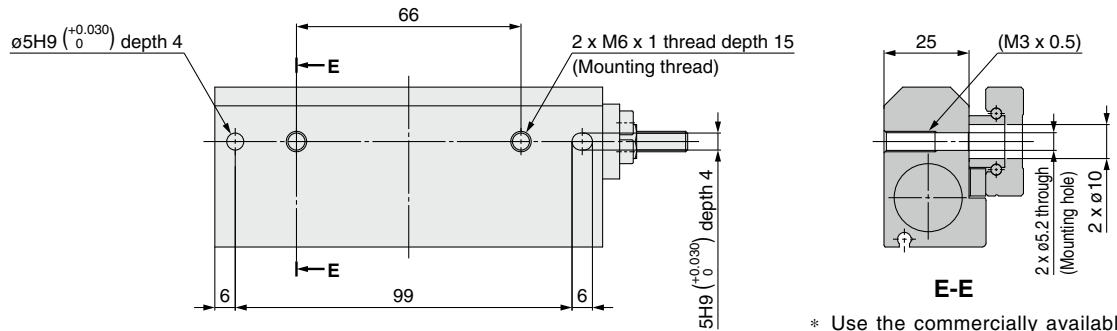

* Use the commercially available hexagon socket head cap screws for body through-hole mounting.

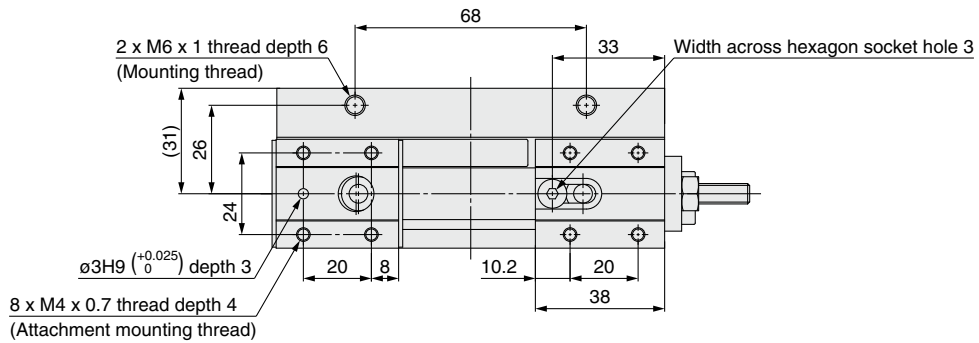
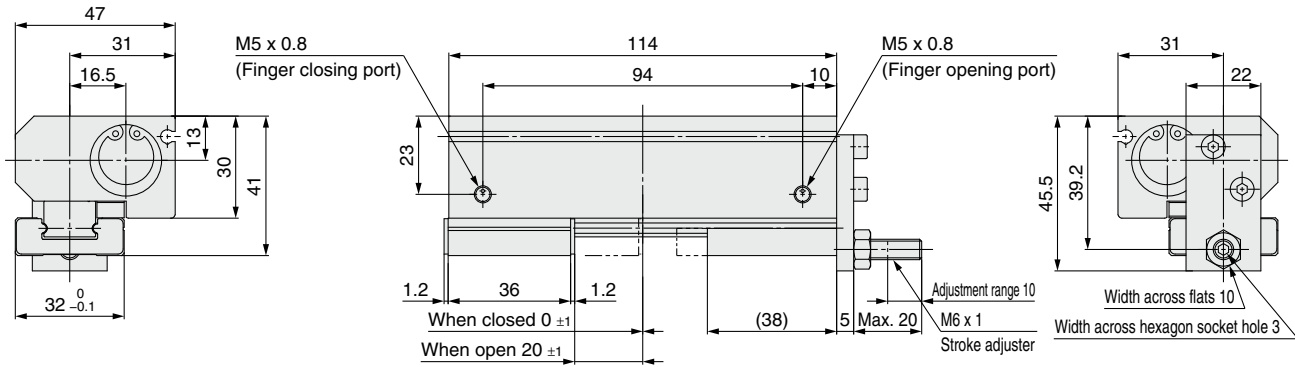

Dimensions of auto switch mounting groove

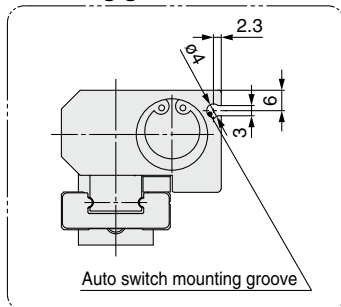

MHF2-□F Series

Dimensions

MHF2-20FD2R

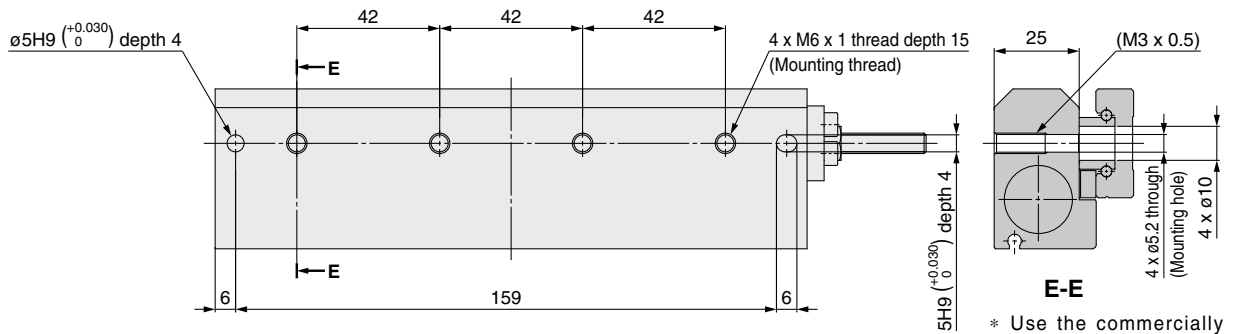

E-E
 * Use the commercially available hexagon socket head cap screws for body through-hole mounting.

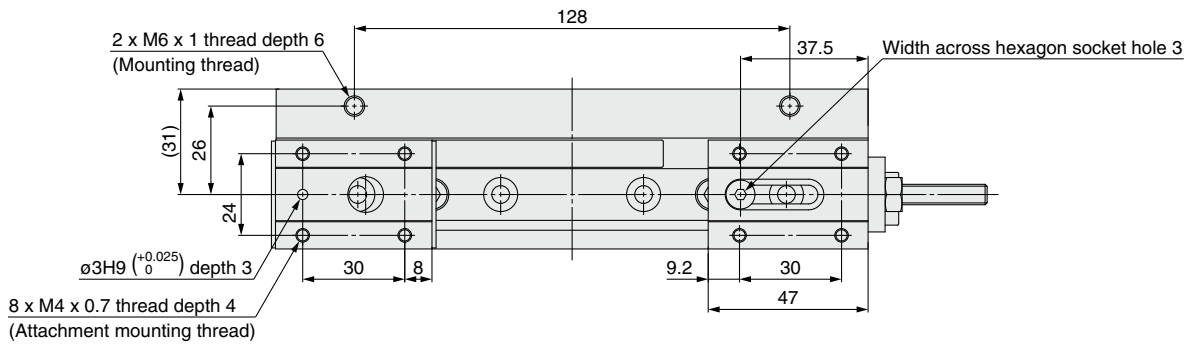
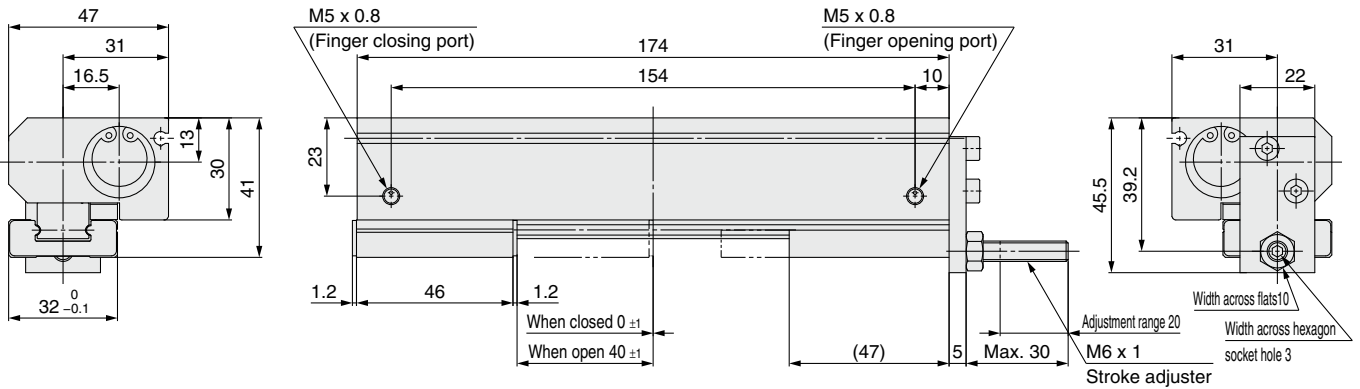

Dimensions of auto switch mounting groove

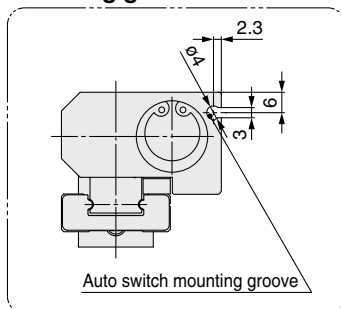

MHF2-□F Series

Auto Switch Installation Examples and Mounting Positions

Various auto switch applications are possible through different combinations of auto switch quantities and detecting positions.

1) External Gripping

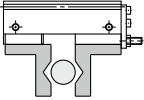
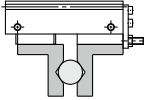
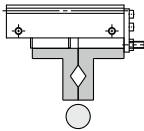
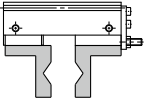
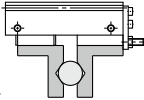
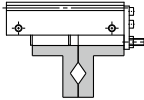
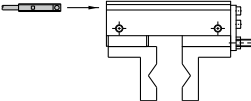
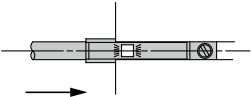
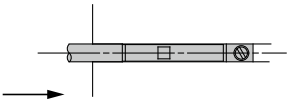
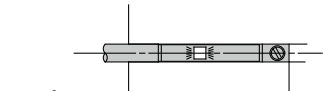
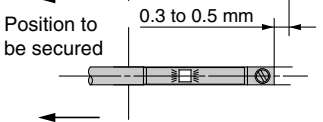
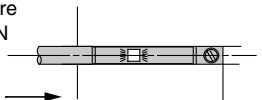
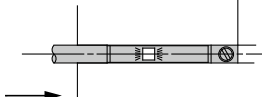
Detection example		① Confirmation of fingers in reset position	② Confirmation of a workpiece held	③ Confirmation of a workpiece released
Position to be detected		Position of fingers fully open 	Position when gripping a workpiece 	Position of fingers fully closed 
Operation of auto switches		When fingers return: Auto switch to turn ON (Light ON)	When gripping a workpiece: Auto switch to turn ON (Light ON)	When a workpiece is not held (Abnormal operation): Auto switch to turn ON (Light ON)
Detection combinations	One auto switch * One position, any of ①, ② and ③ can be detected.	●	●	●
	Two auto switches * Two positions of ①, ② and ③ can be detected.	Pattern A	●	—
		Pattern B	—	●
Pattern C	●	—	●	
How to determine auto switch installation position		Step 1) Fully open the fingers. 	Step 1) Position fingers for gripping a workpiece. 	Step 1) Fully close the fingers. 
At no pressure or low pressure, connect the auto switch to a power supply, and follow the directions.		Step 2) Insert the auto switch into the auto switch mounting groove in the direction as shown in the illustration to the right. 		
		<p>Step 3) Slide the auto switch in the direction of the arrow until the indicator light illuminates.</p>  <p>Step 4) Slide the auto switch further in the direction of the arrow until the indicator light goes out.</p>  <p>Step 5) Slide the auto switch in the opposite direction and fasten it at a position 0.3 to 0.5 mm beyond the position where the indicator light illuminates.</p> <p>Position where light turns ON</p>  <p>Position to be secured</p> 	<p>Step 3) Slide the auto switch in the direction of the arrow until the indicator light illuminates and fasten it at a position 0.3 to 0.5 mm in the direction of the arrow beyond the position where the indicator light illuminates.</p> <p>Position where light turns ON</p>  <p>0.3 to 0.5 mm</p> <p>Position to be secured</p> 	

* It is recommended that gripping of a workpiece be performed close to the center of the finger stroke.
 • When holding a workpiece close at the end of opening/closing stroke of fingers, detecting performance of the combinations listed in the table above may be limited, depending on the hysteresis of an auto switch, etc.

2) Internal Gripping

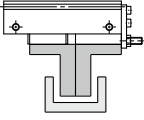
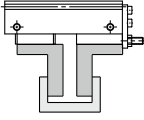
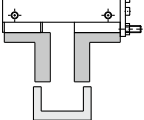
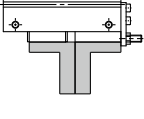
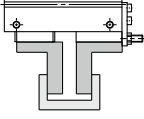
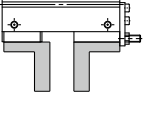
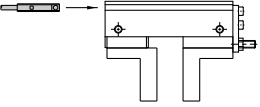
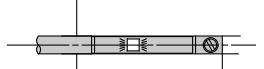
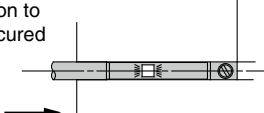
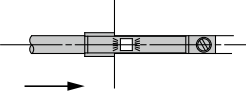
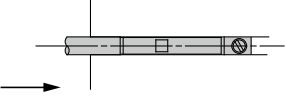
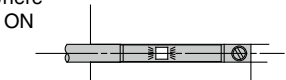
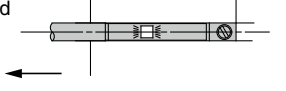
Detection example		① Confirmation of fingers in reset position	② Confirmation of a workpiece held	③ Confirmation of a workpiece released
Position to be detected		Position of fingers fully closed 	Position when gripping a workpiece 	Position of fingers fully open 
Operation of auto switches		When fingers return: Auto switch to turn ON (Light ON)	When gripping a workpiece: Auto switch to turn ON (Light ON)	When a workpiece is not held (Abnormal operation): Auto switch to turn ON (Light ON)
Detection combinations	One auto switch * One position, any of ①, ② and ③ can be detected.	●	●	●
	Two auto switches * Two positions of ①, ② and ③ can be detected.	●	●	—
		—	●	●
	Pattern	●	—	●
		●	—	●
How to determine auto switch installation position		Step 1) Fully close the fingers. 	Step 1) Position fingers for gripping a workpiece. 	Step 1) Fully open the fingers. 
At no pressure or low pressure, connect the auto switch to a power supply, and follow the directions.		Step 2) Insert the auto switch into the auto switch mounting groove in the direction as shown in the illustration to the right. 		
		<p>Step 3) Slide the auto switch in the direction of the arrow until the indicator light illuminates and fasten it at a position 0.3 to 0.5 mm in the direction of the arrow beyond the position where the indicator light illuminates.</p> <p>Position where light turns ON </p> <p>0.3 to 0.5 mm</p> <p>Position to be secured </p>	<p>Step 3) Slide the auto switch in the direction of the arrow until the indicator light illuminates.</p> <p></p> <p>Step 4) Slide the auto switch further in the direction of the arrow until the indicator light goes out.</p> <p></p> <p>Step 5) Slide the auto switch in the opposite direction and fasten it at a position 0.3 to 0.5 mm beyond the position where the indicator light illuminates.</p> <p>Position where light turns ON </p> <p>0.3 to 0.5 mm</p> <p>Position to be secured </p>	

* It is recommended that gripping of a workpiece be performed close to the center of the finger stroke.
 * When holding a workpiece close at the end of opening/closing stroke of fingers, detecting performance of the combinations listed in the table above may be limited, depending on the hysteresis of an auto switch, etc.

Auto Switch Hysteresis

Auto switches have hysteresis similar to micro switches. Use the table below as a guide when adjusting auto switch positions, etc.

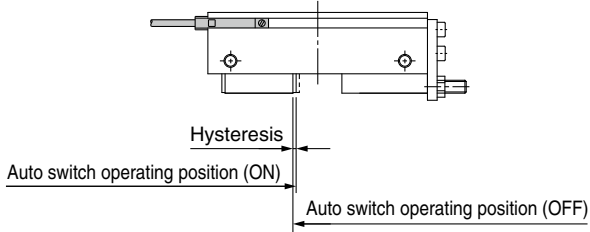

Hysteresis

	D-M9□(V) D-M9□W(V) D-M9□A(V)
MHF2-8FD□	0.2
MHF2-12FD□	0.3
MHF2-16FD□	0.4
MHF2-20FD□	0.4

Auto Switch Mounting

To set the auto switch, insert the auto switch into the auto switch installation groove of the gripper from the direction as shown in the illustration below. After setting the position, tighten the attached auto switch mounting screw with a flat blade watchmaker's screwdriver.

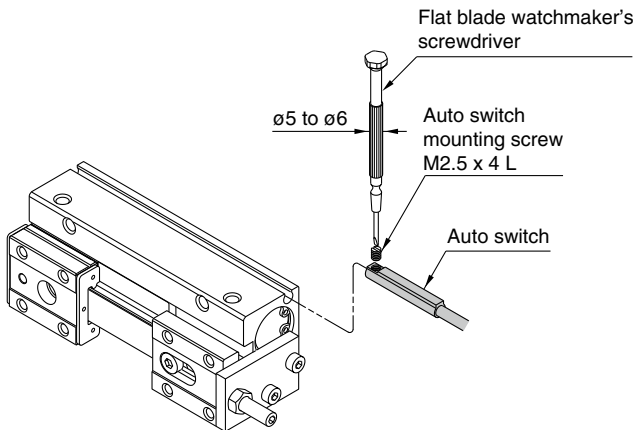

* Use a watchmaker's screwdriver with a grip diameter of 5 to 6 mm to tighten the auto switch mounting screw.
The tightening torque should be 0.05 to 0.15 N·m.

Protrusion of Auto Switch from Edge of Body

- The amount of auto switch protrusion from the body end surface is shown in the table below.
- Use this as a standard when mounting, etc.

Protrusion of Auto Switch

Lead wire type	In-line entry		Perpendicular entry		
	Illustration	Auto switch	Finger position	Auto switch	
Model	D-M9□ D-M9□W	D-M9□A	D-M9□V D-M9□WV	D-M9AV	
MHF2-8FD	Open	6.5	8.5	4.5	6.5
	Closed	6.5	8.5	4.5	6.5
MHF2-8FD1	Open	6.5	8.5	4.5	6.5
	Closed	6.5	8.5	4.5	6.5
MHF2-8FD2	Open	4	6	2	4
	Closed	4	6	2	4
MHF2-12FD	Open	3.5	5.5	2	4
	Closed	3.5	5.5	2	4
MHF2-12FD1	Open	1.5	3.5	—	1.5
	Closed	1.5	3.5	—	1.5
MHF2-12FD2	Open	1.5	3.5	—	1.5
	Closed	1.5	3.5	—	1.5
MHF2-16FD	Open	—	1	—	—
	Closed	—	1	—	—
MHF2-16FD1	Open	—	1	—	—
	Closed	—	1	—	—
MHF2-16FD2	Open	—	1	—	—
	Closed	—	1	—	—
MHF2-20FD	Open	—	—	—	—
	Closed	—	—	—	—
MHF2-20FD1	Open	—	—	—	—
	Closed	—	—	—	—
MHF2-20FD2	Open	—	—	—	—
	Closed	—	—	—	—

* There is no protrusion for sections of the table with no values entered.



MHF2-□F Series

Specific Product Precautions 1

Be sure to read this before handling the products. Refer to the back cover for safety instructions. For actuator and auto switch precautions, refer to the “Handling Precautions for SMC Products” and the “Operation Manual” on the SMC website: <https://www.smcworld.com>

Mounting

Warning

1. Do not scratch or dent the air gripper by dropping or bumping it when mounting.

Even a slight deformation can cause inaccuracy or malfunction.

2. Do not exceed the maximum tightening torque when mounting attachments.

Tightening with a torque above the maximum torque can cause malfunction, while insufficient tightening torque can lead to attachments loosening and falling.

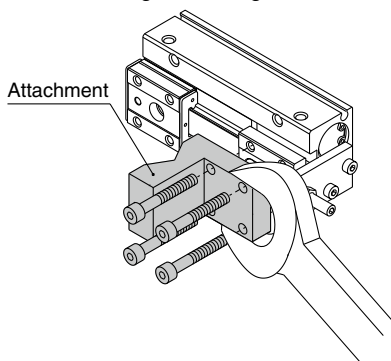

Model	Bolt	Max. tightening torque [N·m]
MHF2-8□D□	M2.5 x 0.45	0.36
MHF2-12□D□	M3 x 0.5	0.63
MHF2-16□D□	M4 x 0.7	1.5
MHF2-20□D□	M4 x 0.7	1.5

3. When tightening the screw to mount the air gripper, apply an appropriate tightening torque below maximum tightening torque.

Tightening with a torque above the maximum torque can cause malfunction, while insufficient tightening torque can lead to attachments loosening and falling.

How to Mount Air Grippers

Top mounting (Body tapped)

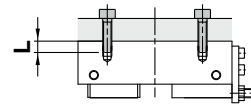

Model	Bolt	Max. tightening torque [N·m]	Max. screw-in depth L [mm]
MHF2-8□D	M3 x 0.5	0.95	7
MHF2-12□D	M4 x 0.7	2.2	10
MHF2-16□D	M5 x 0.8	4.5	12
MHF2-20□D	M6 x 1	7.8	15

Bottom mounting (Body tapped and through-holes)

● Body tapped

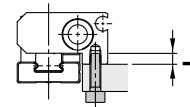

Model	Bolt	Max. tightening torque [N·m]	Max. screw-in depth L [mm]
MHF2-8□D	M3 x 0.5	0.63	4
MHF2-12□D	M4 x 0.7	1.5	5
MHF2-16□D	M5 x 0.8	3	5.5
MHF2-20□D	M6 x 1	5.2	6

● Body through-holes

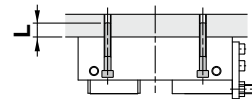

Model	Bolt	Max. tightening torque [N·m]	Screw-in depth L [mm]
MHF2-8□D	M2.5 x 0.45*1	0.36	4
MHF2-12□D	M3 x 0.5*1	0.63	5.2
MHF2-16□D	M4 x 0.7	1.5	—
MHF2-20□D	M5 x 0.8	3	—

*1 When MHF2-8D□ and MHF2-12D□ are mounted body through-hole, use the attached special screws.

* It is necessary to remove the fixed finger when mounting the gripper using the body through-holes. Refer to 1 of “Fixed Finger Position Adjustment” on page 26 for the recommended tightening torques.



MHF2-□F Series

Specific Product Precautions 2

Be sure to read this before handling the products. Refer to the back cover for safety instructions. For actuator and auto switch precautions, refer to the “Handling Precautions for SMC Products” and the “Operation Manual” on the SMC website: <https://www.smcworld.com>

Fixed Finger Position Adjustment

⚠ Caution

1. Make sure that hexagon socket thin head cap screw and adjustment nut are correctly tightened before using the gripper.

Tighten the screws with the specified torques shown in the table below.

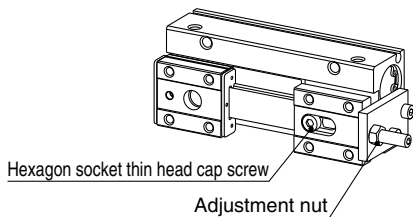

Model	Tightening torque for hexagon socket thin head cap screw [N·m]	Tightening torque for adjustment nut [N·m]
MHF2-8□D	0.63 to 1.14	0.63
MHF2-12□D	1.5 to 2.7	1.5
MHF2-16□D	1.5 to 2.7	3
MHF2-20□D	3 to 5.4	5.2

2. Tighten the fixed finger with the adjustment bolt abutting against the finger.

If load is not applied to the adjustment bolt, for example, if a gap exists between the fixed finger and adjustment bolt, dislocation of the fixed finger can occur.

3. When adjusting the position of the fixed finger after mounting the attachment, make sure that the attachment has a runoff space to allow for tightening the hexagon socket thin head cap screw.

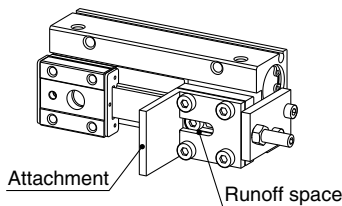

Operating Environment

⚠ Caution

Use caution for the anti-corrosiveness of the linear guide unit.

Martensitic stainless steel is used for the finger guide rail. However, the anti-corrosiveness of this steel is inferior to that of austenitic stainless steel. In particular, rust may be generated in environments where water droplets are likely to adhere due to condensation, etc.

Handling

⚠ Caution

How to Locate Finger and Attachment

● Positioning in the finger's open/close direction

Position the finger and the attachment by inserting the finger's pin into the attachment's pin insertion hole.

Provide the following pin insertion hole dimensions: shaft-basis fitting dimension **C** for the open/close direction; slotted hole with relief **B** for the cross direction.

● Positioning in the finger's cross direction

Perform the positioning from the reference plane of the finger and the side A of the attachment.

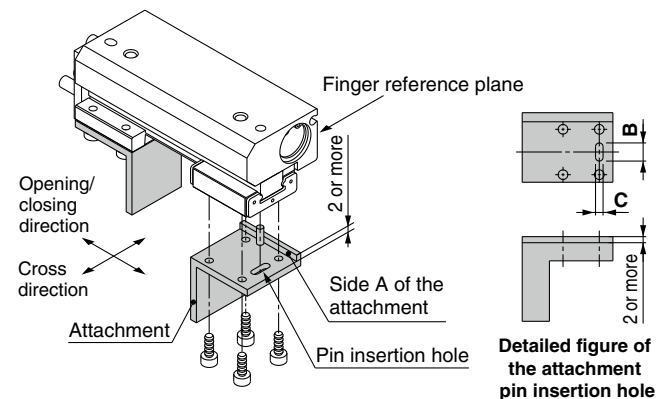



Finite orbit type guide is used in the actuator finger part. By using this, when there are inertial force which cause by movements or rotation to the actuator, steel ball will move to one side and this will cause a large resistance and degrade the accuracy. When there are inertial force which cause by movements or rotation to the actuator, operate the finger to full stroke.

Especially in long stroke type, the accuracy of the finger may degrade.

Safety Instructions

These safety instructions are intended to prevent hazardous situations and/or equipment damage. These instructions indicate the level of potential hazard with the labels of “**Caution**,” “**Warning**” or “**Danger**.” They are all important notes for safety and must be followed in addition to International Standards (ISO/IEC)*1), and other safety regulations.

 **Caution:** **Caution** indicates a hazard with a low level of risk which, if not avoided, could result in minor or moderate injury.

 **Warning:** **Warning** indicates a hazard with a medium level of risk which, if not avoided, could result in death or serious injury.

 **Danger:** **Danger** indicates a hazard with a high level of risk which, if not avoided, will result in death or serious injury.

*1) ISO 4414: Pneumatic fluid power – General rules relating to systems.
ISO 4413: Hydraulic fluid power – General rules relating to systems.
IEC 60204-1: Safety of machinery – Electrical equipment of machines.
(Part 1: General requirements)
ISO 10218-1: Manipulating industrial robots – Safety.
etc.

Warning

1. The compatibility of the product is the responsibility of the person who designs the equipment or decides its specifications.

Since the product specified here is used under various operating conditions, its compatibility with specific equipment must be decided by the person who designs the equipment or decides its specifications based on necessary analysis and test results. The expected performance and safety assurance of the equipment will be the responsibility of the person who has determined its compatibility with the product. This person should also continuously review all specifications of the product referring to its latest catalog information, with a view to giving due consideration to any possibility of equipment failure when configuring the equipment.

2. Only personnel with appropriate training should operate machinery and equipment.

The product specified here may become unsafe if handled incorrectly. The assembly, operation and maintenance of machines or equipment including our products must be performed by an operator who is appropriately trained and experienced.

3. Do not service or attempt to remove product and machinery/equipment until safety is confirmed.

1. The inspection and maintenance of machinery/equipment should only be performed after measures to prevent falling or runaway of the driven objects have been confirmed.
2. When the product is to be removed, confirm that the safety measures as mentioned above are implemented and the power from any appropriate source is cut, and read and understand the specific product precautions of all relevant products carefully.
3. Before machinery/equipment is restarted, take measures to prevent unexpected operation and malfunction.

4. Contact SMC beforehand and take special consideration of safety measures if the product is to be used in any of the following conditions.

1. Conditions and environments outside of the given specifications, or use outdoors or in a place exposed to direct sunlight.
2. Installation on equipment in conjunction with atomic energy, railways, air navigation, space, shipping, vehicles, military, medical treatment, combustion and recreation, or equipment in contact with food and beverages, emergency stop circuits, clutch and brake circuits in press applications, safety equipment or other applications unsuitable for the standard specifications described in the product catalog.
3. An application which could have negative effects on people, property, or animals requiring special safety analysis.
4. Use in an interlock circuit, which requires the provision of double interlock for possible failure by using a mechanical protective function, and periodical checks to confirm proper operation.

Caution

1. The product is provided for use in manufacturing industries.

The product herein described is basically provided for peaceful use in manufacturing industries.
If considering using the product in other industries, consult SMC beforehand and exchange specifications or a contract if necessary.
If anything is unclear, contact your nearest sales branch.

Limited warranty and Disclaimer/ Compliance Requirements

The product used is subject to the following “Limited warranty and Disclaimer” and “Compliance Requirements”.

Read and accept them before using the product.

Limited warranty and Disclaimer

1. The warranty period of the product is 1 year in service or 1.5 years after the product is delivered, whichever is first.*2)
Also, the product may have specified durability, running distance or replacement parts. Please consult your nearest sales branch.
2. For any failure or damage reported within the warranty period which is clearly our responsibility, a replacement product or necessary parts will be provided.
This limited warranty applies only to our product independently, and not to any other damage incurred due to the failure of the product.
3. Prior to using SMC products, please read and understand the warranty terms and disclaimers noted in the specified catalog for the particular products.

*2) Vacuum pads are excluded from this 1 year warranty.

A vacuum pad is a consumable part, so it is warranted for a year after it is delivered.
Also, even within the warranty period, the wear of a product due to the use of the vacuum pad or failure due to the deterioration of rubber material are not covered by the limited warranty.

Compliance Requirements

1. The use of SMC products with production equipment for the manufacture of weapons of mass destruction (WMD) or any other weapon is strictly prohibited.
2. The exports of SMC products or technology from one country to another are governed by the relevant security laws and regulations of the countries involved in the transaction. Prior to the shipment of a SMC product to another country, assure that all local rules governing that export are known and followed.

Caution

SMC products are not intended for use as instruments for legal metrology.

Measurement instruments that SMC manufactures or sells have not been qualified by type approval tests relevant to the metrology (measurement) laws of each country. Therefore, SMC products cannot be used for business or certification ordained by the metrology (measurement) laws of each country.

Safety Instructions

Be sure to read the “Handling Precautions for SMC Products” (M-E03-3) and “Operation Manual” before use.